



Markets Served:

- Clinics
- Educational Facilities
- Laboratories
- Food & Beverage Production
- Food Service / Restaurants
- Grocery
- Healthcare / Hospitals / Bio-Pharmaceutical
- Hospitality / Lodging
- Manufacturing

**The Culligan® LC Series
REVERSE OSMOSIS SYSTEM**

A Compact, Energy-Efficient Solution for Applications Requiring up to 200 GPD of RO Water.

The Culligan® LC RO Series adapts our exclusive Aqua-Clear® technology to the higher output requirements of light commercial applications. The modular design of the system allows users to avoid over-or under-sizing for their water filtration needs* by changing the quantity and capacity of the membrane cartridges in use. The cartridge head adapters and integrated wall-mount bracket make for easy installation and even easier maintenance over the long lifetime of the system.

The LC Reverse Osmosis Series forms part of the Culligan® Commercial and Industrial product line. Our portfolio offers durable, high-quality equipment with a world recognized brand 80 years in the making. Our expansive dealership network provides experienced, technical service and sales personnel who understand the unique requirements of users in every market. From planning and designing the equipment through the installation and maintenance phases, Culligan® offers options that help deliver the highest quality of water to meet your needs. Contact Culligan® today to learn more about the LC Reverse Osmosis Series.

CULLIGAN® COMMERCIAL AND INDUSTRIAL SOLUTIONS ADVANTAGES:

- Simple System Integration
- Global Product Platform
- Flexible Configurations
- Quick Delivery / Easy Installation

**Contaminants may not necessarily be in your water.*



SYSTEM SPECIFICATIONS

Warranty

Culligan's LC Series Reverse Osmosis Systems are backed by a one year limited warranty against defects in material and workmanship. See printed warranty for details. Culligan® will provide a copy of the warranty upon request.



System Specifications

Specification	US (Metric)
Inlet Pressure, minimum (dynamic) without booster pump	60 psig (414 kPa)
Inlet Pressure, maximum	120 psig (828 kPa)
Feed Water Temperature	33–100° F (1–38° C)
Turbidity, maximum	10.0 NTU
pH Range	5 – 10
Free Chloride	3.0 ppm
Chloramine, maximum	3.0 mg/L
Total Dissolved Solids, maximum	2500 mg/L
Silt Density Index, maximum	3.0
Langlier Saturation Index, maximum	0.0
Iron, maximum	1.0 mg/L
Hardness	0-10 gpg
Operating Weight	25-30 lbs (11-14 kg)

Examples of RO Applications

- Food & Beverage — Improved taste and increased cost savings
- Ice Production / Drinking Water — Reduces scaling; improves taste and clarity
- Restaurants — Improves steamer operation; reduces scaling in dish washers
- Humidification — Reduces scaling and dusting
- Grocery Stores — Prevents scaling in vegetable misters
- Laboratories — Improves the lifetime and performance of autoclaves and other steam sterilization equipment
- Horticulture — Reduces leaf spotting and mineral build up in potting soils
- Water Jet Cutting — Improves operating efficiency

Standard Features

- Pre-assembled wall-mount bracket allows for a quick, simplified installation process
- Hydraulic operation does not require electricity
- Automatic shut-off valve saves water when the optional pressure storage tank is full
- Exclusive quick change membranes manufactured with corrosion resistant materials
- Dual thin low energy, film composite RO membrane cartridges to reduce dissolved minerals, colloids, particles, organics and silica†
- A 5-micron sediment cartridge to pre-filter suspended particles for extended component life
- Granular activated carbon cartridges to reduce elements like chlorine and organics that cause water to taste and smell unpleasant
- Waste flow restrictors maintain the proper recovery ratio of product-to-feed water flow

Optional Features & Accessories

- Booster pump kit to increase feed pressure by ~40 psi. This kits includes the pump, transformer, pressure switch and solenoid valve
- Pressurized product water storage tank

† Do not use on water that is microbiologically unsafe or of unknown quality without adequate disinfection before or after system.

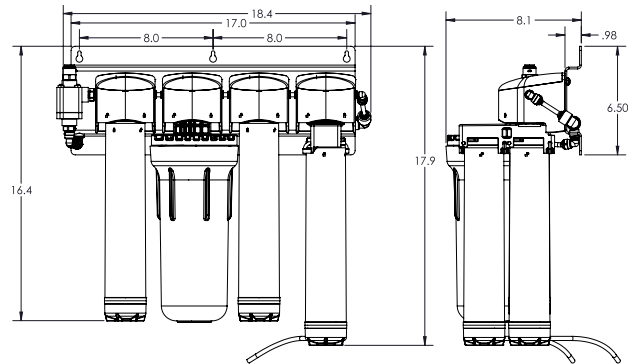

LC Series Reverse Osmosis System

Model	Nominal Capacity ¹	Design Recovery % ²	Dimensions	Automatic Shut-off Valve	5 Micron Sediment Pre-filter Cartridge	Sump Containing 10" GAC Filter	Secondary GAC Filter Cartridge	100 gpd RO Cartridges	75 gpd RO Cartridges
LCRO-100AC	100 gpd (378 lpd)	30%	18.4" w. x 8.1" d. x 17.9" h. (46.7 cm x 20.6 cm x 45.5 cm)	✓	✓	✓	✓	1X	
LCRO-150AC	150 gpd (567 lpd)			✓	✓	✓	✓		2X
LCRO-200AC	200 gpd (756 lpd)			✓	✓	✓	✓	2X	

¹ Approximate nominal capacity based on properly pretreated feed water of 600 ppm TDS as NaCl, 77° F, Silt Density Index below 3.0, and 60 psi applied pressure supplying water to atmosphere. Productivity will vary depending on the feed water conditions.
² Actual recovery will depend on feed water source, SDI, temperature and product back pressure.



www.culligan.com • 866-787-4293

For 80 years, Culligan® has made better water. Our global network, comprised of 800+ dealers and international licensees in over 90 countries, is dedicated to addressing your water-related problems. As a worldwide leader in water treatment, our sales representatives and service technicians are familiar with the local water conditions in your area. Being global and local position us to deliver customized solutions to commercial and industrial water issues that affect your business and your bottom line.

All trademarks used herein are registered trademarks of Culligan International Company.

Products manufactured or marketed by Culligan® and its affiliates are protected by patents issued or pending in the United States and other countries.

Culligan® reserves the right to change the specifications referred to in this literature at any time, without prior notice.